

EVEF

**EASTMAN**

**STRAIGHT KNIFE CUTTING MACHINE  
INSTRUCTION BOOK AND PARTS LIST**

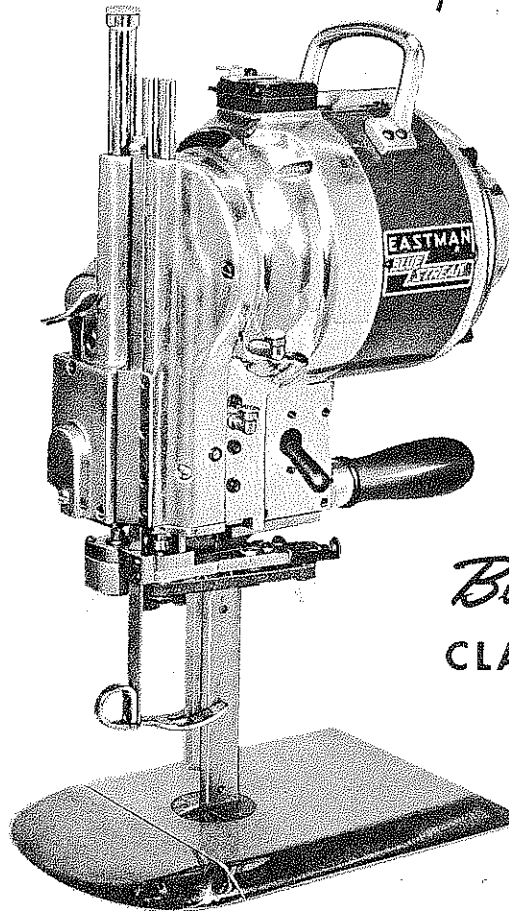

*Blue Streak*  
CLASS 555, 565, 623

779 WASHINGTON STREET, BUFFALO, N. Y.

PHONE AREA  
85

3

## OPERATION, LUBRICATION AND CARE

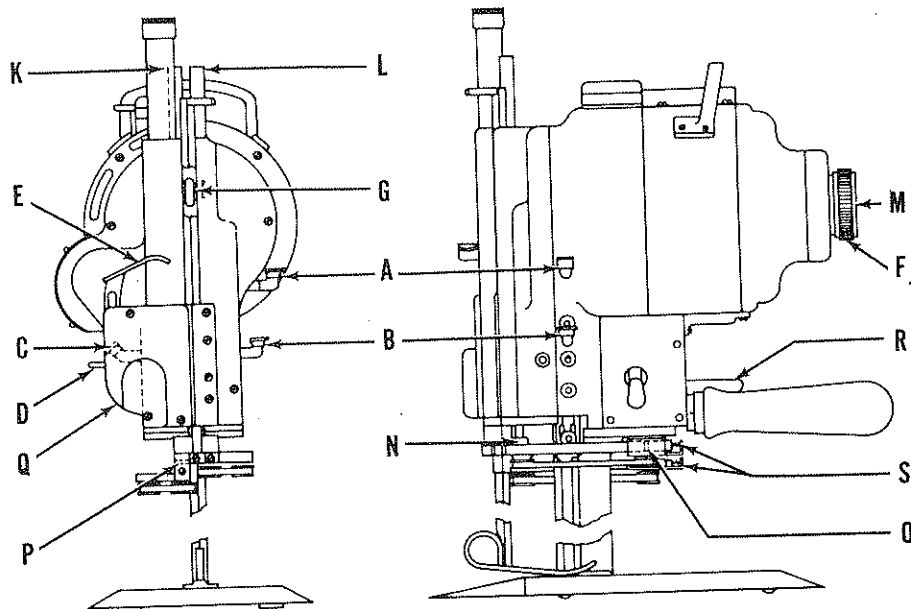

BLUE STREAK CLASS 555, 565, and 623

### BEFORE STARTING

IN COLD WEATHER, PLEASE KEEP MACHINE IN WARM PLACE

Fill oil cups A, B and C. Make sure sharpener is in locked position. If sharpener is not in locked position, trip lock lever D up, then press sharpener operating lever E halfway down and move sharpener up into locked position. Push in turning knob F and turn the machine over a few revolutions by hand to see if knife moves easily. Connect attachment plug and start machine.

#### WARNING

For 3-phase machines direction of rotation must be as indicated by arrow on turning knob F. See tag attached to all 3-phase machines for instructions.

For the first week or two, or after the machine has been idle for any length of time, the motor should be turned on and off a few times before allowing it to run continuously. This permits the oil to warm up and easily into the closely fit moving parts.

Printed in U.S.A.

## LUBRICATION

EVERY 2 HOURS — DAILY	ONCE A WEEK	ONCE A MONTH
Fill oil cups A-B-C. Oil connecting rod bearing G. To oil, drop pressure foot rod and turn crank until you see connecting rod shaft through hole G. Use can with small spout (furnished with machine). Insert spout in hole in shaft and oil.	One drop only to: Tubes at K & L Turning Knob at M Pulley Shaft N Belt Pulleys O	Remove plug at P and insert grease tube. Squeeze an amount about equal to the size of a pea into opening.

DO NOT USE AN EXCESS AMOUNT OF OIL

### CAUTION

Do not use sewing machine oil. It is entirely too light for cutting machine lubrication. For best results use specially compounded Eastman oil or at least a good grade of No. 30 motor oil.

## CARE OF MACHINE

Use air hose or bellows and blow lint out of motor and sharpener twice a week. Remove cover Q and clean out lint around screw mechanism in sharpener once a week. Remove knife and clean knife slides with slot cleaner at least once a day. Remove lint from rollers in base plate as necessary. To prevent undue accumulation of lint, do not oil plate rollers. If rollers stick, remove from plate and wash in cleaning solvent.

## TO SHARPEN THE KNIFE

Take the machine out of the lay. Drop pressure foot by means of pressure foot lever R located next to machine operating handle. Press lever E downward with a slow, firm pressure to engage sharpening mechanism. Too fast lever action may cause lever to lock. If this occurs, lift lever D and start over. After a few tries you will feel correct operating pressure.

### WARNING

Do not operate sharpener without knife in machine or the sharpener will be damaged. Do not shut off motor while sharpener is in motion.

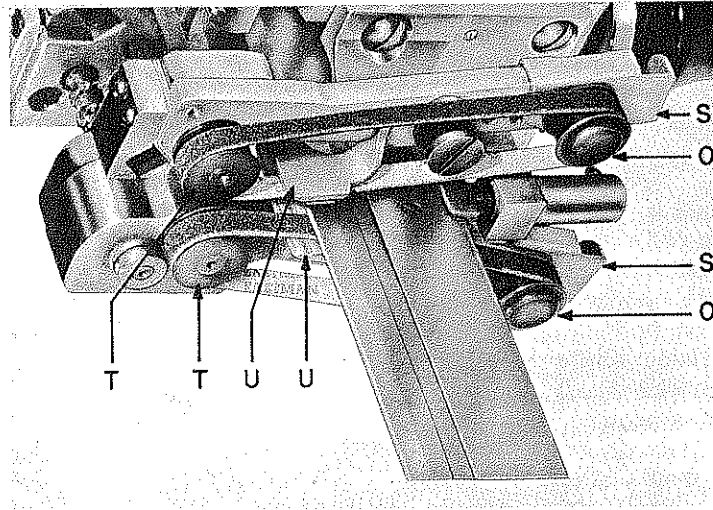

### TO CHANGE SHARPENER BELTS

Push brackets S inward to release tension and remove worn belts. Place new belt over front pulley T, then between sharpener shoe U and knife and then over rear pulley O. Sharpener belts are available in 4 grits: Rough, Coarse, Medium and Fine. When changing from one grit sharpener belt to another, sharpener shoes U should be adjusted to maintain a uniform cutting edge.

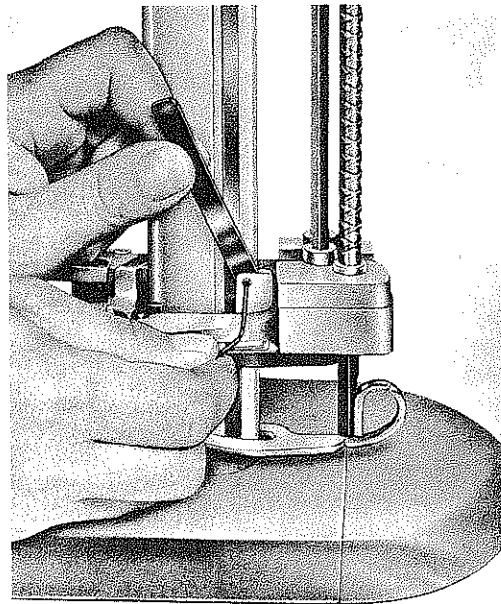

### TO ADJUST SHARPENER SHOES

Install a new knife and new emery belts. Lower the knife to the bottom of the stroke with the machine turning knob F. Lower the sharpener by hand, by holding the sharpener operating lever E halfway down to its neutral position. To determine the correct sharpener shoe setting, insert .010 feeler gauge between the set screw and the knife and adjust the set screw as shown in the illustration.

## TO REMOVE SHARPENER

Press lever E approximately halfway down to neutral position and lower the sharpener bracket by hand.

### NOTE

If lever E is pressed too far down (beyond neutral position) it will lock the sharpener bracket. To release, lift lever D and start over.

Remove guide bracket. Press lever E to a neutral position and raise sharpener bracket to original (top) position. Remove four hold down nuts V and remove sharpener.

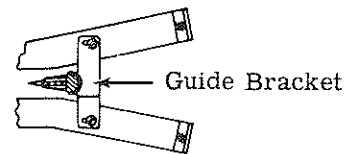
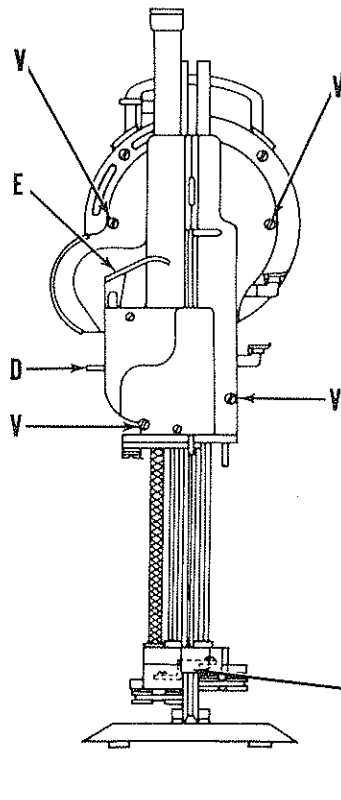

## TO REPLACE RUBBER DRIVER

Remove sharpener from machine. See instructions above. Press lever E to neutral position and lower sharpener bracket until an inch of the square shafts W are exposed. Hold square shaft W with wrench. Wrench position on shaft should be as close as possible to sharpener housing. Use spanner wrench to remove drive pulley by turning clockwise as indicated by arrow (pulley has left-hand thread). Cut old rubber driver from pulley. Clean surface of pulley. Apply a coat of cement (Pliobond or equivalent) to face of pulley. Place one edge of new rubber driver between flanges of pulley. Hold pulley in vise and stretch rubber driver over flanges with screwdriver. Reassemble pulley on sharpener. Reassemble sharpener on machine.

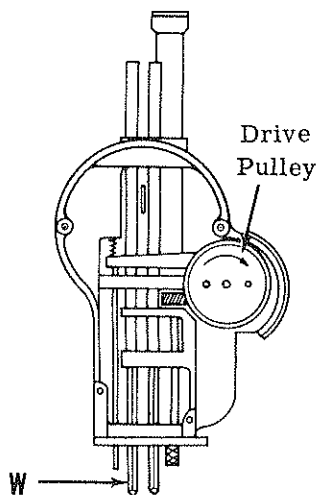



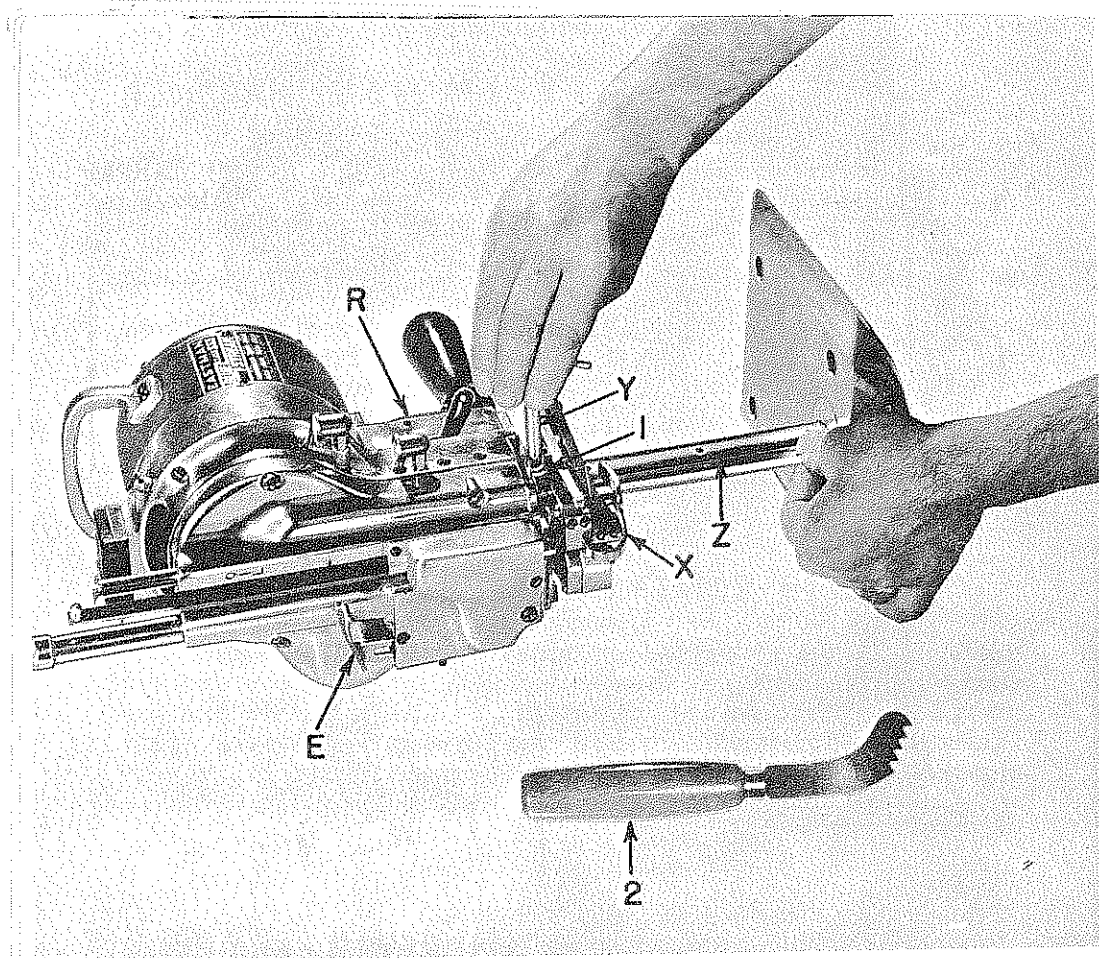

## TO CHANGE THE KNIFE

Make sure sharpener is in locked position. Raise pressure foot X to top position by means of pressure foot lever R. Lay machine on table as shown. Press in turning knob F and turn knife to bottom position. Insert T-handle knife bolt wrench Y as shown and loosen knife locknut (1). Remove knife through bottom of standard Z. After removing knife, clean knife slot in standard with slot cleaner (2). Insert new knife in knife slot. Be sure to set knife tightly up against knife holding stud and at the same time hold the bottom of the knife against the back of the slot in the standard when tightening knife locknut. After tightening knife locknut, check to see if knife runs freely in standard by rotating turning knob. Install new sharpener belts and operate sharpener three or four times before starting to cut.

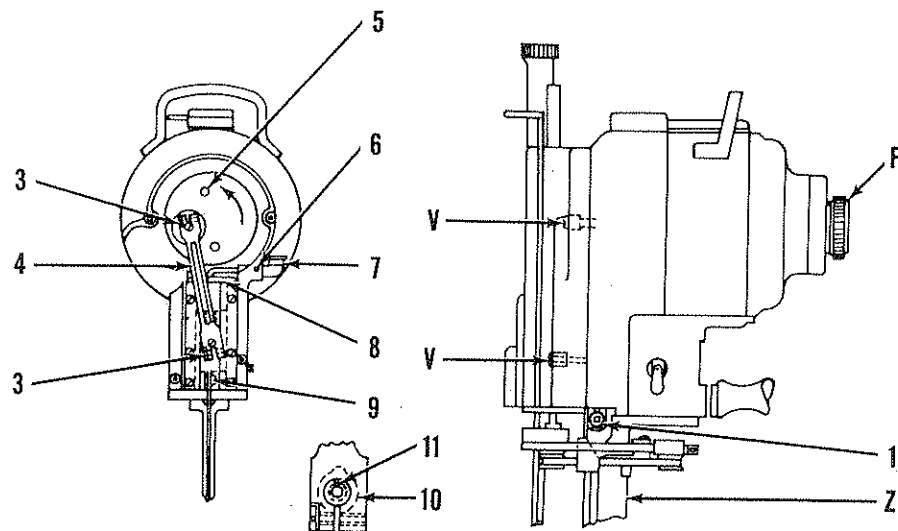

## TO FREE FROZEN GUIDES

Remove sharpener from machine as explained previously. Remove knife. Loosen screws (3) and remove connecting rod (4). Insert drift pin in hole (5) in crank and tap with light hammer in direction of arrow. This will loosen crank. Remove crank. Loosen set screw (6) using No. 564 Allen Key (.078 dia.) and remove oiler and tube (7). Remove oil pad holder (8). Remove crosshead(9) from guides. Use a fiber or brass rod against the bottom of crosshead and drive crosshead out through the top of the guides.

### NOTE

If wrist pin is frozen in crosshead, drive wrist pin out of crosshead with soft punch. Polish wrist pin and hole in crosshead with fine emery cloth.

Hone rough spot on bearing surface of crosshead against a flat oil-stone until smooth. Examine guides. If any evidence of high spot, remove with scraper and clean. Oil bearing surface of guides, insert crosshead and reassemble machine. Be sure washer (10) is in place between connecting rod and crosshead.

### CAUTION

Wrist pin must be installed with notch (11) at top center. Otherwise flow of oil to wrist pin bearing will be cut off.

Run machine for approximately one-half hour, oiling guides frequently before putting machine back into production.

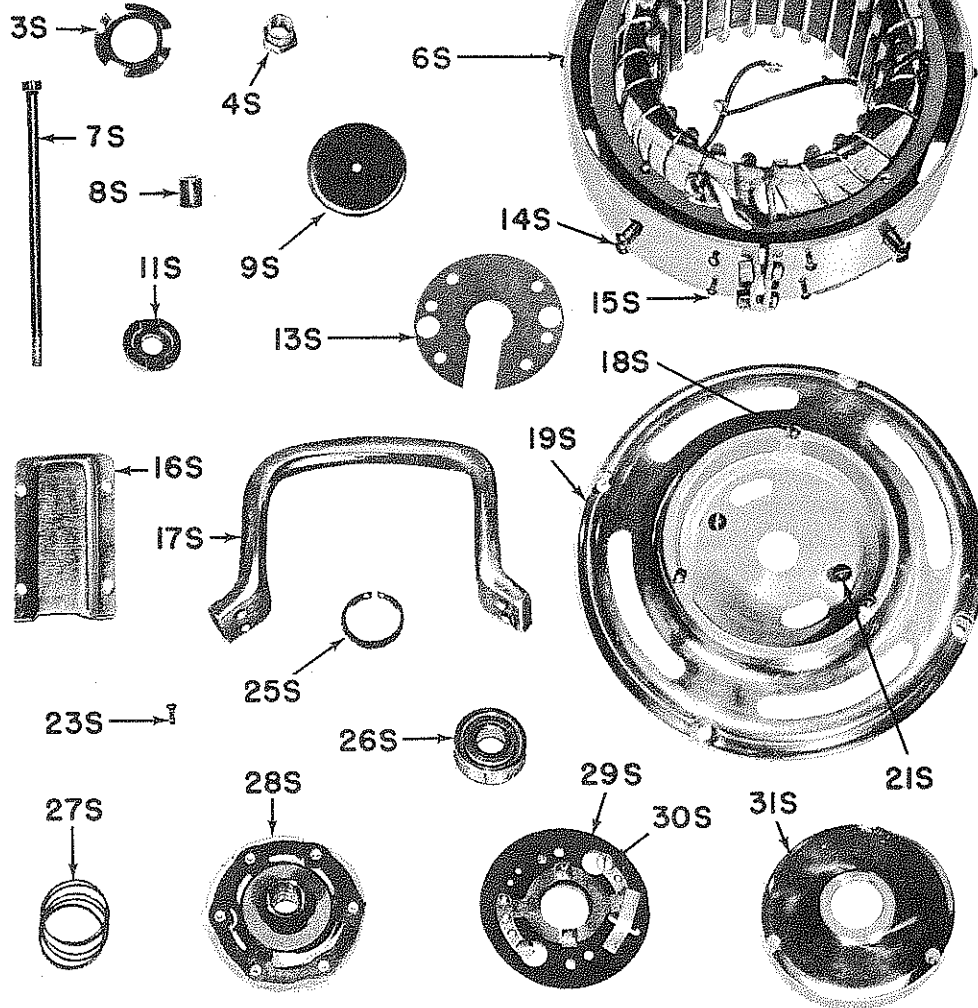
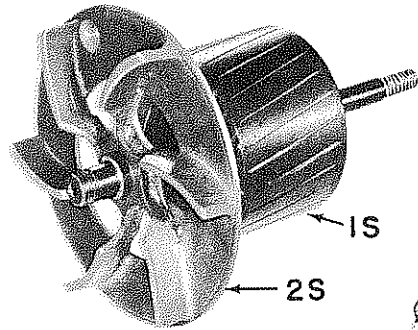
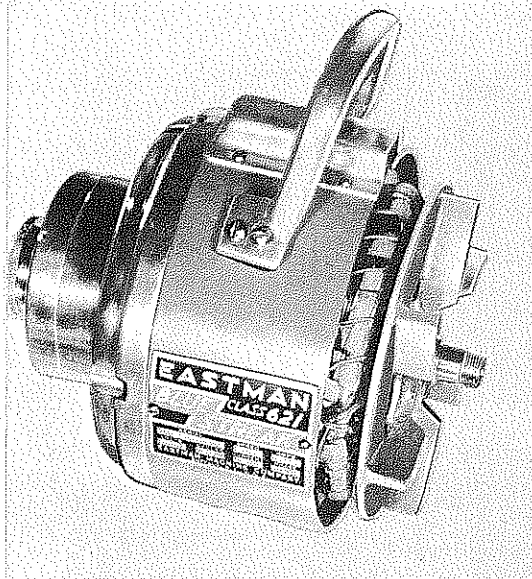



## MOTOR ASSEMBLY, CLASS 623

(FOR CLASS 555 AND 565 SEE PAGE 17)

List No.	Part Description	Part No.
1S	Rotor with Shaft	513C3-X
2S	Rotor Fan	10C1-X
3S	Rear Ball Bearing Spring Washer	12C1-12
4S	Shaft Lock Nut	4C1-145
6S	Stator with Band	514C3-X
7S	Front to Rear Bearing Screws (4)	20C3-23
8S	Front to Rear Bearing Nut (4)	4C1-99
9S	Turning Knob	13C1-9
11S	Clutch Nut	4C2-87
13S	Cut-Out Switch Insulation	8C5-3
14S	Carrying Handle Screws (4)	8-32x5/8R.H.
15S	Cover Over Stator Band Screws (4)	4-36x1/8R.H.
16S	Cover Over Stator Band	53C11-65
17S	Carrying Handle	22C1-24
18S	Dust Cap Screws (3)	4-36x5/8Fil.H.
19S	Rear Bearing Housing	90C1-X
21S	Automatic Cut-Out Switch to Bearing Screws (2)	8x32x5/8R.H.
23S	Screw for Rear Bearing Lock Nut	4-36x1/4Fil.H.
25S	Retaining Ring	1.8C6-16
26S	Rear Ball Bearing	90C6-28
27S	Clutch Spring	34C1-51
28S*	Automatic Cut-Out	597C2-1*
29S	Automatic Cut-Out Switch	580C1-46
30S	Automatic Cut-Out Terminal Screws (2)	20C12-2
31S	Dust Cap	30C1-6D

\* Please Specify if for 1800 RPM or 50 Cycle Machines

### IMPORTANT ORDERING INSTRUCTIONS

Number in parenthesis indicates number of parts per assembly. Where the letter X follows a part number, be sure to give the model and serial numbers shown on the machine for which the part is required.

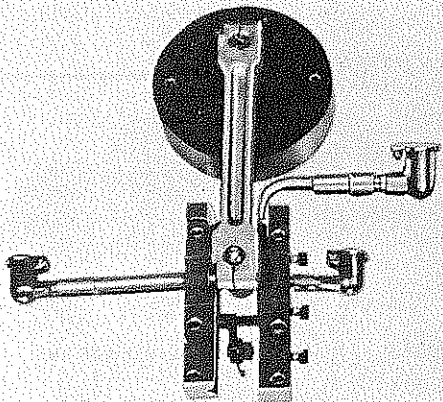

32S



33S



34S

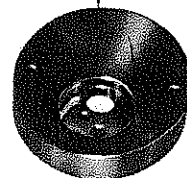

35S



36S



37S



38S



39S



40S



41S



42S



43S



44S



45S



48S



49S



50S



52S



61S



53S

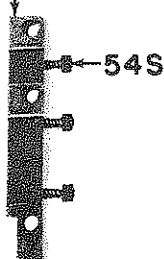

55S



56S



56S

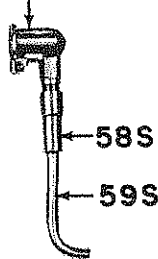

57S



60S



62S



63S



## CRANK AND GUIDE ASSEMBLY

List No.	Part Description	Part No.
32S	Screw for Brg. Shaft	20C12-78
33S	Crank Ball Bearing	90C6
34S	Crank	85C1-X
35S	Shaft for Ball Bearing	11C12-27
36S	Crank Ball Bearing Lock Nut	4C1-132
37S	Oil Pad Holder	727C1-5
38S	Oil Pad Holder Screws (2)	4-36x1/4R.H.
39S	Knife Lock Washer	12C1-24
40S	Wrist Pin Plug	54C4-32
41S	Wrist Pin	17C4-6
42S	Guide Hold Down Screws (2)	20C12-122
43S	Nut for Guide Screw (3)	4C2-91
44S	Guide Hold Down Screws (4)	20C12-123
45S	Cross Head	579C2-17
46S	Knife Lock Bolt	24C1-3
48S	Guide Washers (4)	12C15-14
49S	Guide Adjustment Screws (3)	20C13-15
50S	Oil Cup (R. H. Guide)	72C4-16
51S	Oil Tube (L. H. Guide)	73C1-3
52S	Guide Adjusting Nut (3)	4C3-8
53S	L. H. Guide	70C1-X
54S	Guide Lock Screws (3)	20C13-14
55S	R. H. Guide	70C1-X
56S	Oil Cup (L. H. Guide & Crosshead) (2)	72C4-15
57S	Oil Tube (L. H. Guide)	73C1-7
58S	Oil Tube for Wrist Pin	73C7-X
59S	Oil Tube for Wrist Pin	73C6-X
60S	Connecting Rod	664C1-X
61S	Connecting Rod Washer	12C15-53
62S	Connecting Rod Clamp Screw (2)	20C5-17
63S	Shakeproof Washer	12C1-21

### IMPORTANT ORDERING INSTRUCTIONS

Number in parenthesis indicates number of parts per assembly. Where the letter X follows a part number, be sure to give the model and serial numbers shown on the machine for which the part is required.

## FRONT BEARING HOUSING

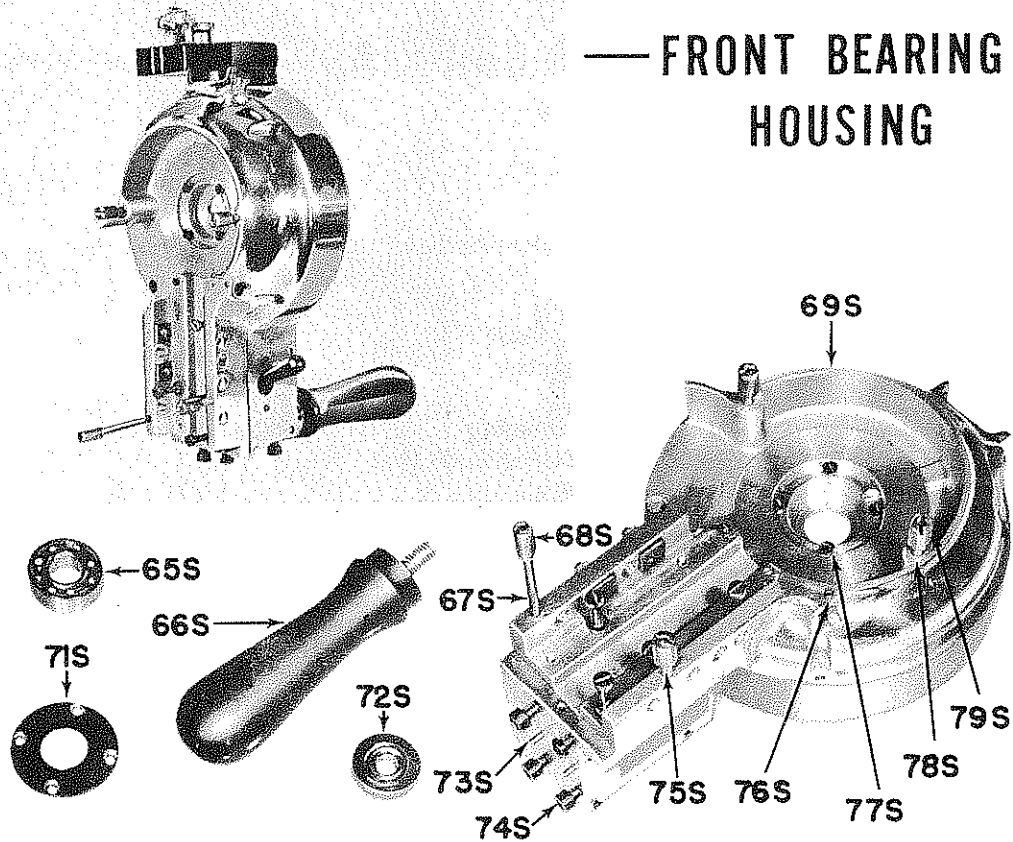

List No.	Part Description	Part No.
65S	Front Ball Bearing	90C6-29
66S	Operating Handle	531C1-53
67S	Stud, Lower L. H. Mounting	15C13-34
68S	Lower L. H. Sharpener hold down Nut	4C1-150
69S	Front Bearing Housing	90C2-X
71S	Front Ball Bearing Retainer	71C3-5
72S	Operating Handle Lock Nut	4C1-111
73S	Standard-to-Bearing Pin (2)	17C1-5
74S	Standard-to-Bearing Screws (4)	20C12-39
75S	Stud, Guard Rod Bracket (2)	15C13-39
76S	Set Screw	20C13-4
77S	Front Ball Bearing Retainer Screws	6-32x5/16Fl.H.
78S	Stud, Upper (2)	15C13-23
79S	Sharpener hold down Nuts (3)	4C1-99

### IMPORTANT ORDERING INSTRUCTIONS

Number in parenthesis indicates number of parts per assembly. Where the letter X follows a part number, be sure to give the model and serial numbers shown on the machine for which the part is required.

# TERMINAL BLOCK, ATTACHMENT PLUG AND SWITCH

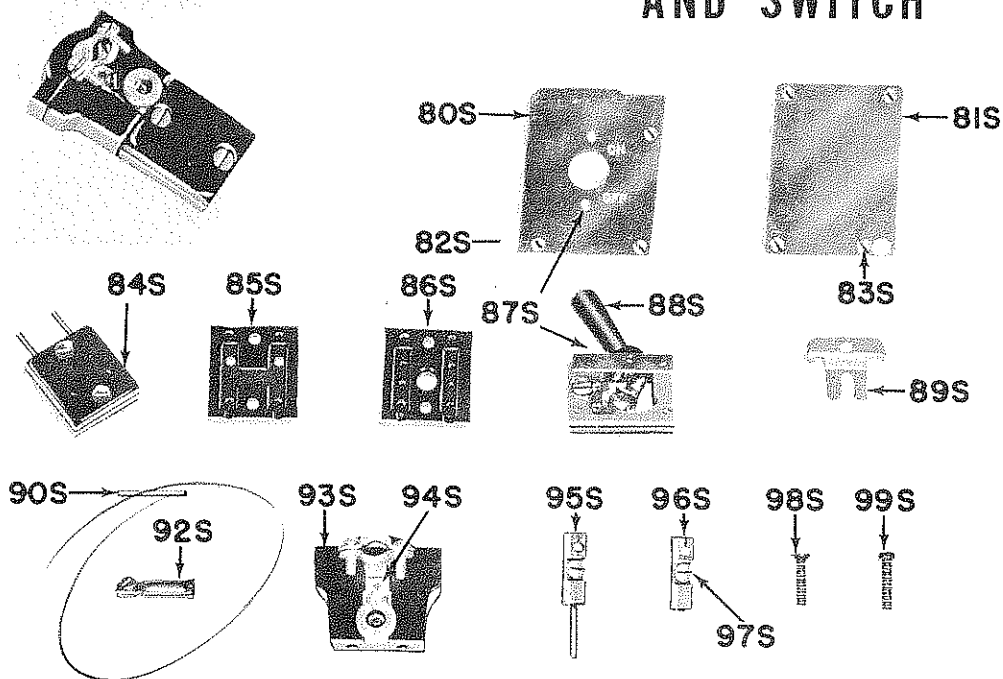

## SINGLE PHASE PARTS

List No.	Part Description	Part No.
80S	Switch Base	52C5-X
81S	Switch Cover	53C2-X
82S	Switch Cover Screws (3)	4-36x1/4O.H.
83S	Switch Base Screws (4)	4-36x1/4O.H.
84S	Terminal Block (Complete)	508C1-19
85S	Terminal Block (top)	51C1-16
86S	Terminal Block (bottom)	51C1-17
87S	Switch Screws (2)	4-36x1/4R.H.
88S	Switch	580C1-14
89S	Ground Clip	79C12-107
90S	Terminal Pin (2)	47C2-4
92S	Terminal Sleeve (2)	47C3-16
93S	Attachment Plug (Complete)	523C1-51
94S	Attachment Plug Clamp	615C1-7
95S	Terminal Contact with Pin (2)	667C1
96S	Terminal Contact	93C2-1
97S	Terminal Screws (2)	20C12-2
98S	Terminal Block Screw (1)	10-32x7/8Fl.H.
99S	Ground Clip Screw (1)	10-32x1 Fil.H.



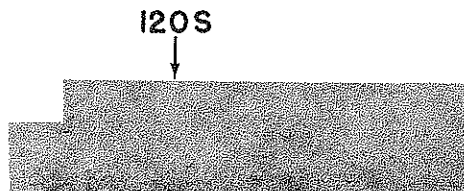
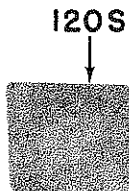
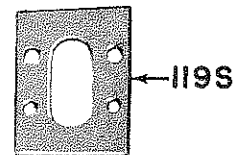
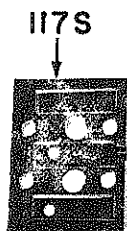
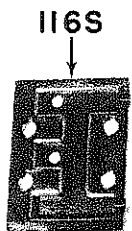
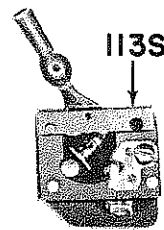
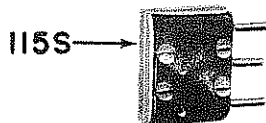
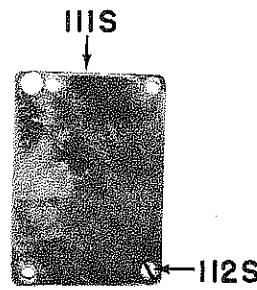
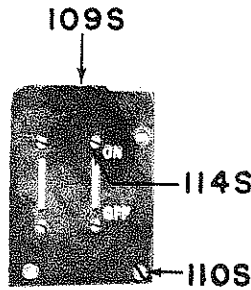
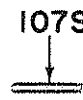
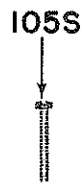
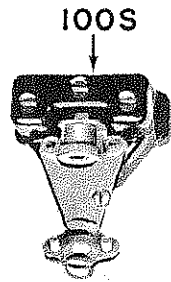
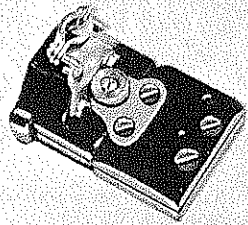

# TERMINAL BLOCK, ATTACHMENT PLUG AND SWITCH

## THREE PHASE PARTS

List No.	Part Description	Part No.
100S	Attachment Plug Complete	523C1-38
101S	Ground Clip	79C12-106
102S	Contact with Pin - Left Hand	667C1-3
103S	Contact with Pin - Right Hand	667C1-1
104S	Contact with Pin - Center	667C1-2
105S	Screws for Terminal Block (2)	10-32x1-1/8"Fl.H.
106S	Screws for Terminal Block (2)	10-32x1-1/8"Fl.H.
107S	Terminal Pin (3)	47C2-9
108S	Attachment Plug Terminal Sleeve (3)	47C3-17
109S	Switch Base	52C5-X
110S	Switch Base Screws (3)	4-36x1/4O.H.
111S	Switch Cover	53C2-X
112S	Switch Cover Screws (4)	4-36x1/4O.H.
113S	3-Phase Switch Complete	580C1-11
114S	Switch to Base Screws (4)	4-36x1/4R.H.
115S	Terminal Block Complete	508C1-22
116S	Terminal Block (Top)	51C1-18
117S	Terminal Block (Bottom)	51C1-19
118S	Attachment Plug Clamp	615C1-5
119S	Terminal Block Adapter	29C6-67
120S	Insulation for 3-phase parts	
	Small Insulation	8C4-11
	Large Insulation	8C4-37

### IMPORTANT ORDERING INSTRUCTIONS

Number in parenthesis indicates number of parts per assembly. Where the letter X follows a part number, be sure to give the model and serial numbers shown on the machine for which the part is required.

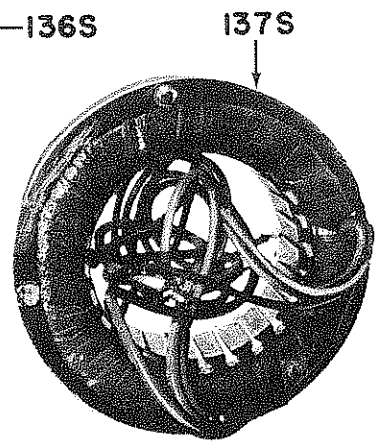
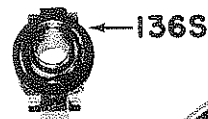
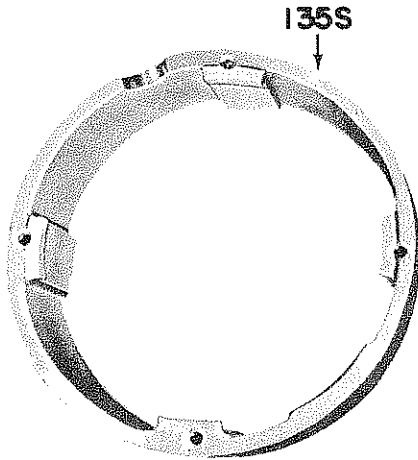
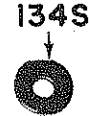
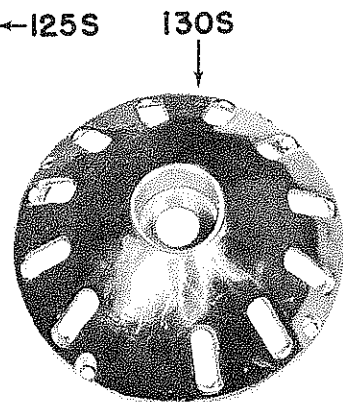
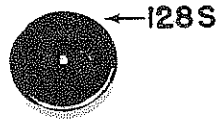
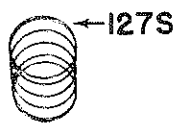
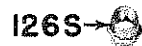
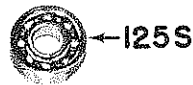
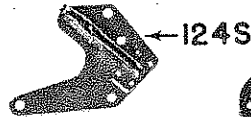
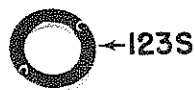
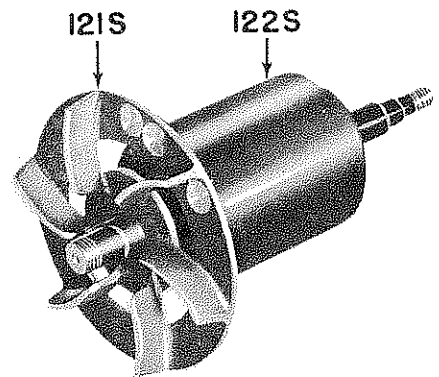
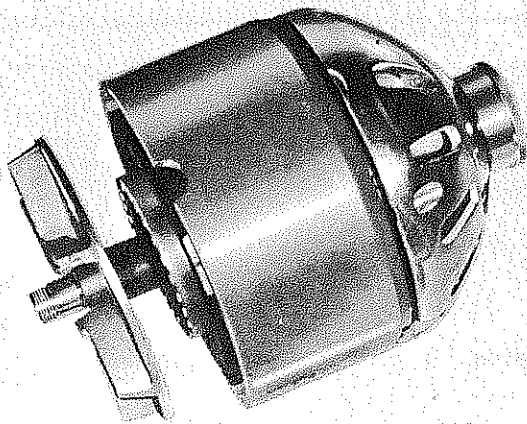

# MOTOR ASSEMBLY, CLASS 555 AND 565

(FOR CLASS 623 SEE PAGE 9)

List No.	Part Description	Part No.
121S	Fan	10C1-X
122S	Rotor With Shaft	513C3-X
123S	Rear Bearing Cap	86C3-18
124S	Cutout Block Assembly	733C1
125S	Rear Ball Bearing	90C6-28
126S	Shaft Lock Nut	4C1-145
127S	Tension Spring	34C1-51
128S	Turning Knob	13C1-9
130S	Rear Bearing Housing	90C1-112
131S	Cutout Cover	53C11-41
132S	Cutout Cover Screws (3)	4-36x1/4FLH.
133S	Clutch Disk	115C1-7
134S	Clutch Nut	4C2-98
135S	Stator Ring	18C2-X
136S	Automatic Cutout	597C1-10
137S	Stator	575C1-X
139S	Grommet	207C1

## IMPORTANT ORDERING INSTRUCTIONS

Number in parenthesis indicates number of parts per assembly. Where the letter X follows a part number, be sure to give the model and serial numbers shown on the machine for which the part is required.

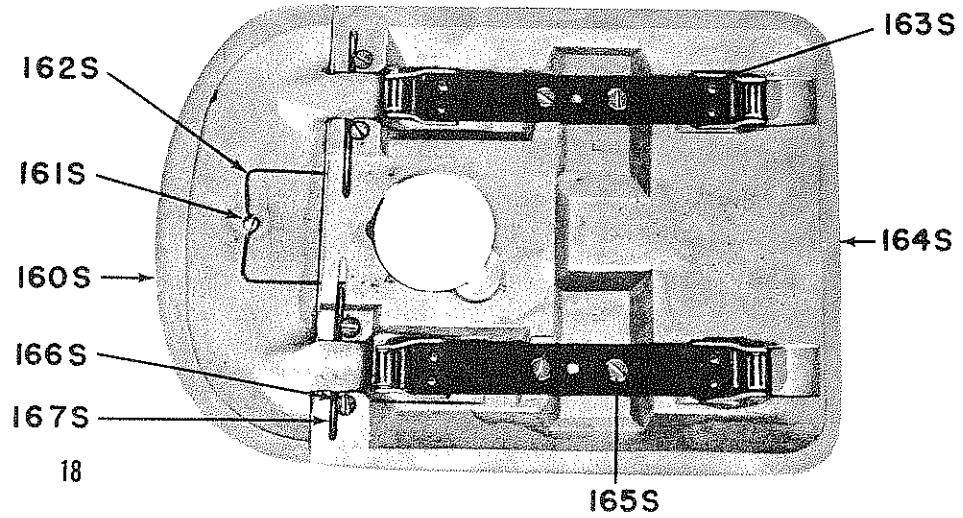
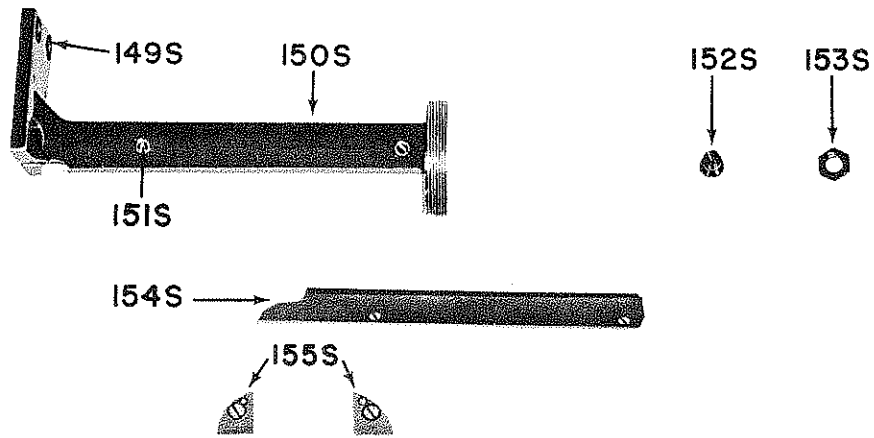
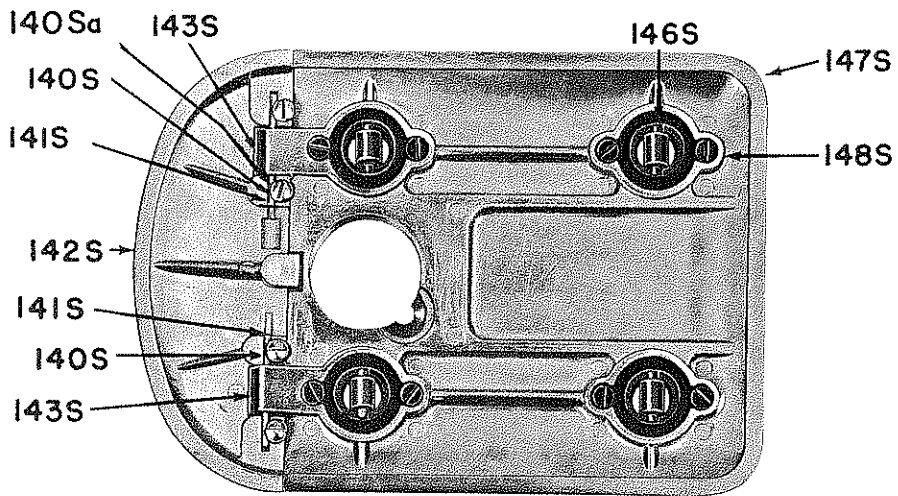



## STANDARD AND BASE PLATES

List No.	Part Description	Part No.
<b>BASE PLATE (RUBBER MOUNTED ROLLERS)</b>		
140Sa	Lock Washer (4)	12C1-35
140S	Hinge Pin Clamp Screw (4)	20C13-51
141S	Hinge Pin, Short (2)	17C6-9
142S	Plate Wing	60C1-XR
143S	Plate Wing Tension Spring (2)	34C1-57
146S	Rubber Mounted Roller (Complete)	532C2-3
147S	Plate Complete (Rubber Mounted Rollers)	505C3-XR
148S	Clamp Screws for Rollers (8)	20C5-12

### STANDARD

149S	Standard to Bearing (4) Screws	20C12-39
150S *	Standard (Complete with Knife Slides and Throat Plates)	528C1-X *
151S	Knife Slide Screw	20C12-19
152S	Plate Bolt	24C4
153S	Plate Bolt Nut	4C2-2
154S *	Knife Slides (Complete with Screws)	643C1-X *
155S	Throat Plates With Screws and Pins	79C4-12/13

\* Specify Knife Size When Ordering Standard or Knife Slides

### BASE PLATE (SPRING MOUNTED ROLLERS)

160S	Plate Wing	60C1-XS
161S	Plate Wing Tension Spring Screw (1) 6-32x1/4R.H.	
162S	Plate Wing Tension Spring	34C1-2
163S	Plate Roller Complete (2)	532C1-X
164S	Plate Complete (Spring Roller Type)	505C3-XS
165S	Plate Roller Screw (4)	20C5-18
166S	Hinge Pin Clamp Screw (4)	20C5
167S	Hinge Pin (2)	17C6

### IMPORTANT ORDERING INSTRUCTIONS

Number in parenthesis indicates number of parts per assembly. Where the letter X follows a part number, be sure to give the model and serial numbers shown on the machine for which the part is required.

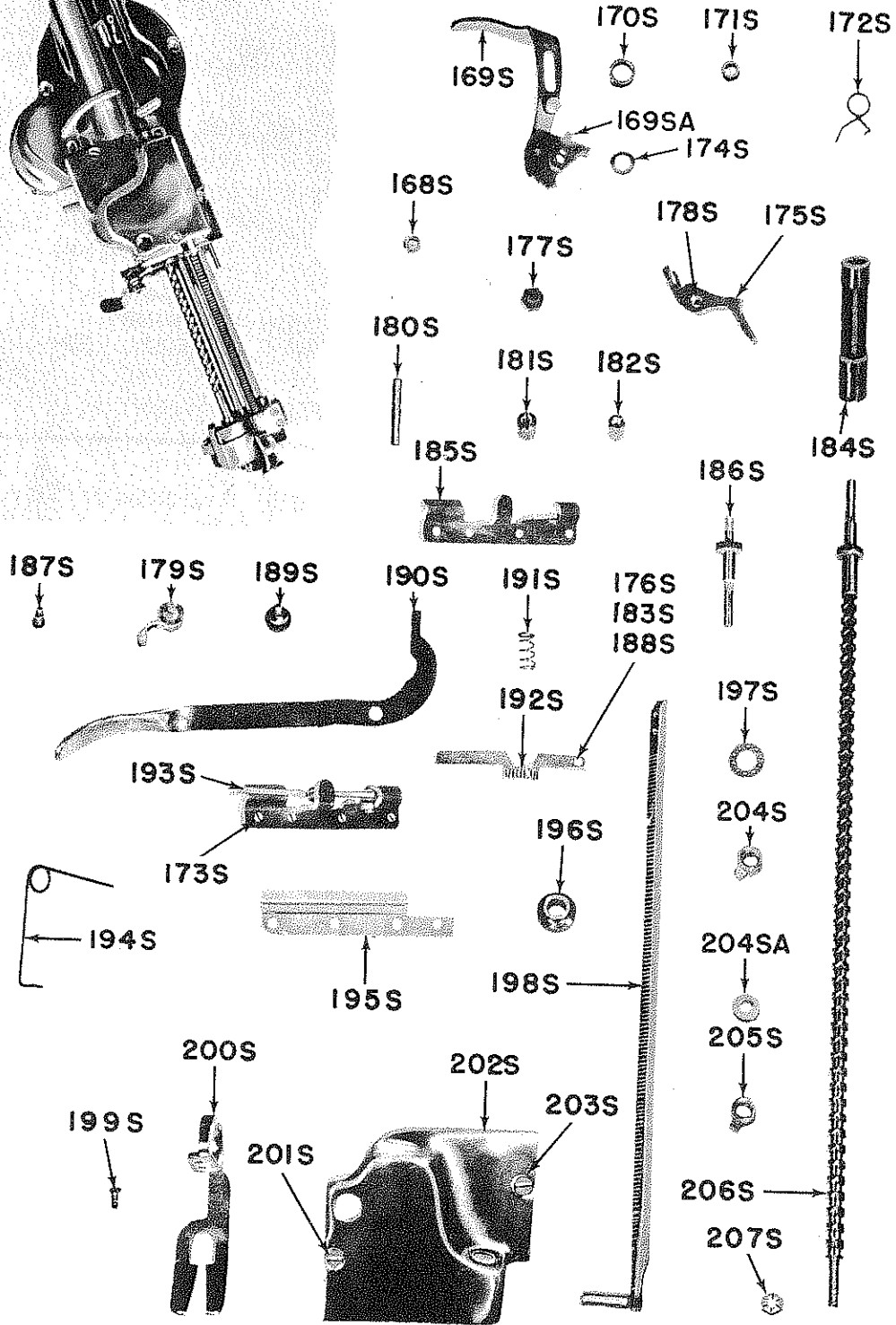
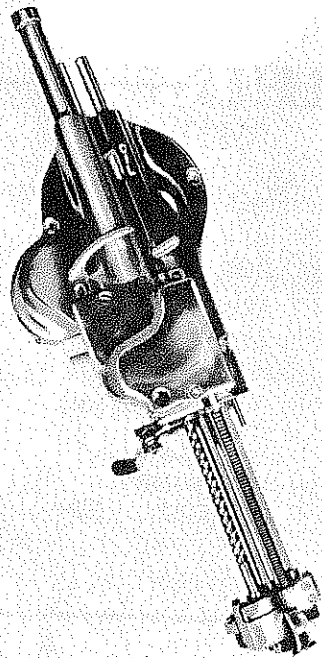

## AUTOMATIC SHARPENER ASSEMBLY

List No.	Part Description	Part No.
168S	Screw for Release Lever	20C12-119
169S	Release Lever with Cam	621C1-7
169Sa	Set Screw for Cam	20C12-118
170S	Bearing for Cam Shaft (Rear)	90C4-43
171S	Bearing for Cam Shaft (Front)	90C4-44
172S	Spring for Latch	34C10-107
173S	Pres. Foot Lock Bracket Screws (4)	6-32x5/16R.H.
174S	Spring Washer for Release Lever	12C15-57
175S	Latch for Cam	97C3-35
176S	Screw for Pressure Foot Lock	20C12-137
177S	Stud for Release Lever	15C13-38
178S	Screw for Latch	20C12-113
179S	Cam Spring	34C1-20
180S	Shaft for Cam	11C12-54
181S	Sharpener Hold Down Nuts (3)	4C1-99
182S	Sharpener Hold Down Nut	4C1-150
183S	Washer for Lock Bracket	12C15-69
184S	Spacer Tube	73C7-X
185S	Pressure Foot Lock Bracket	553C1-8
186S	Screw Shaft Extension	147C1-26
187S	Cam Shaft Spring Screw	20C12-13
188S	Nut (6-32 Flexlock) for Pres. Ft. Lock	4C1-161
189S	Pressure Foot Lever Screw	20C4-17
190S	Pressure Foot Lever	57C7-39
191S	Spring for Pressure Foot Lock	34C8-12
192S	Lock (only) Pressure Foot	171C1-16
193S	Pressure Foot Lock Bracket (complete)	553C1-7
194S	Spring for Pressure Foot Lever	34C10-100
195S	Slide for Pressure Foot Rod	66C1-52
196S	Bearing for Screw Shaft	90C4-58
197S	Thrust Ball Bearing (2)	658C1-1
198S*	Pressure Foot Rod	605C1-X*
199S	Screw (2) for Pressure Foot Shoe	20C12-117
200S	Pressure Foot Shoe	68C1-183
201S	Screw for Cover	6-32x3/4Fl.H.
202S	Cover Over Cam	53C11-72
203S	Screw for Cover	6-32x3/8Fl.H.
204S	Nut for Screw Shaft L.H.	4C2-90
204Sa	Thrust Washer for Nuts	12C15-54
205S	Nut for Screw Shaft R.H.	4C2-89
206S*	Screw Shaft with Extension	713C2-X*
207S	Stop Nut for Screw Shaft	4C1-149

\* Please Specify Knife Size

### IMPORTANT ORDERING INSTRUCTIONS

Number in parenthesis indicates number of parts per assembly. Where the letter X follows a part number, be sure to give the model and serial numbers shown on the machine for which the part is required.

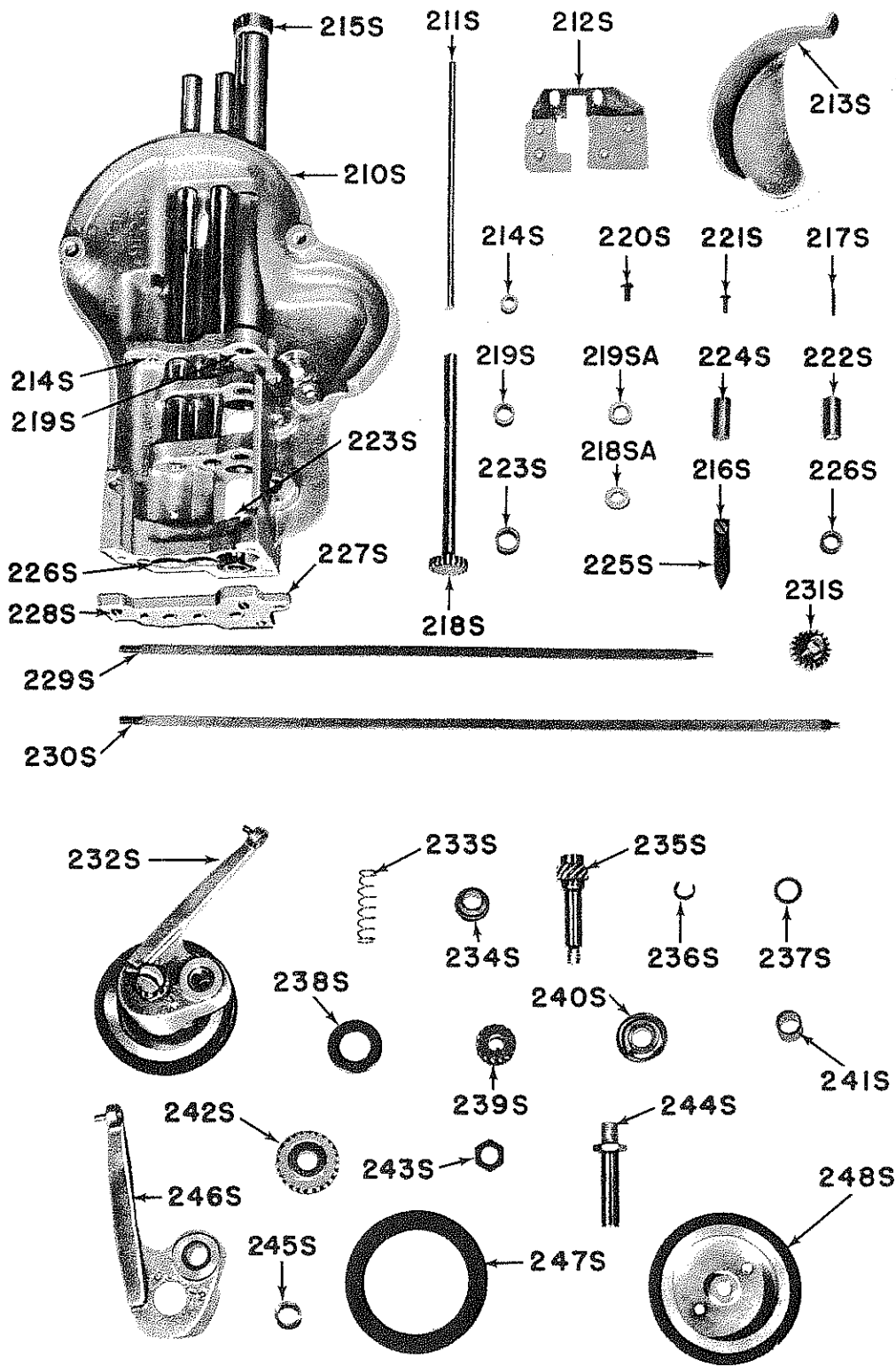

## SHARPENER HOUSING AND BELL CRANK ASSEMBLY

List No.	Part Description	Part No.
210S	Sharpener Housing	732C1-X
211S	Push Rod	65C6-75
212S	Oil Pad & Holder	727C1-6
213S	Cover for Driver	53C11-X
214S	Bearing for Push Rod (2)	90C4-41
215S	Cap for Tube	86C7-22
216S	Screw for Spreader Pin	6-32x1/2Fl.H.
217S	Roll Pin for Push Rod	17C15-103
218S	Driver Shaft with Gear	718C1-12
218Sa	Thrust Washer	12C15-29
219S	Bearing for Drive Shaft (Upper)	90C4-48
219Sa	Bearing for Drive Shaft	90C4-42
220S	Screws (2) for Oil Pad	6-32X1/4R.H.
221S	Screws (2) for Cover	4-36x1/8R.H.
222S	Right Hand Follower Nut	4C2-85
223S	Bushing for Drive Shaft (Lower)	90C4-29
224S	Left Hand Follower Nut	4C2-86
225S	Spreader Pin	17C15-113
226S	Bearing for Gears (2)	90C4-33
227S	Bottom Plate	79C12-163
228S	Bottom Plate Screws (3)	8-32x1/4Fl.H.
229S	R.H. & L.H. Square Shaft 5"-6"-7"-8"	11C12XS
230S	R.H. & L.H. Square Shaft 9" & 10" (Specify "Right" or "Left" when ordering parts)	11C12XL
231S	Spur Gear (2)	87C3-44
232S*	Bell Crank Complete	584C3-14*
233S	Spring for Bell Crank	34C10-89
234S	Spacer for Ball Bearings 90C6-24	55C4-41
235S*	Gear & Shaft	87C3-42*
236S	Retaining Ring for 11C12-64	18C6-8
237S	Washer for 11C12-64	12C15-52
238S	Lock Nut for Ball Bearing 90C6-24	4C1-143
239S	L.H. Spiral Gear with Key	724C1-3
240S	Ball Bearing for Crank (2)	90C6-24
241S	Bearing for Gear 627C1-5	90C4-53
242S	Idler Gear with Bushing	627C1-5
243S	Lock Nut for Crank Shaft	4C1-147
244S	Shaft for Crank	11C12-64
245S	Bearing for Crank	90C4-34
246S*	Bell Crank with Pin & Bushing	584C2-1*
247S*	Rubber Drivers	200C1-9*
248S*	Driver Pulley with Driver	602C1-7*

\* For 1800 RPM Machines, Please List 1800 RPM Before Part Number



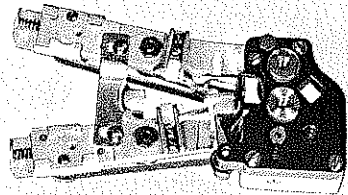

250S

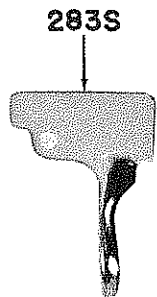
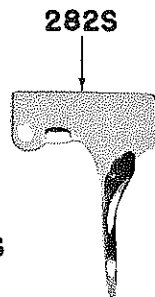
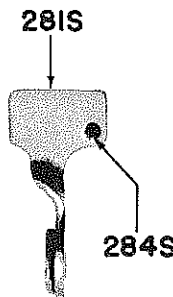
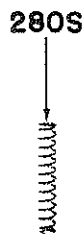
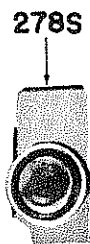
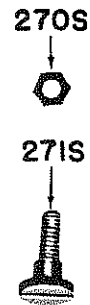
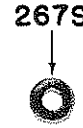
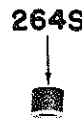
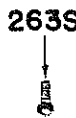
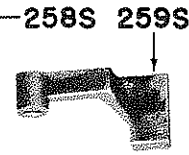
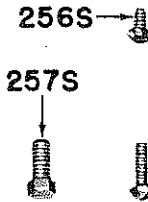
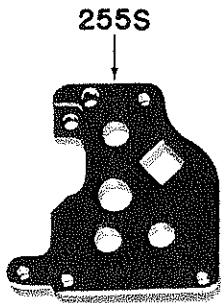
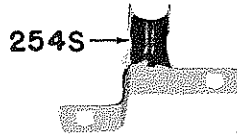
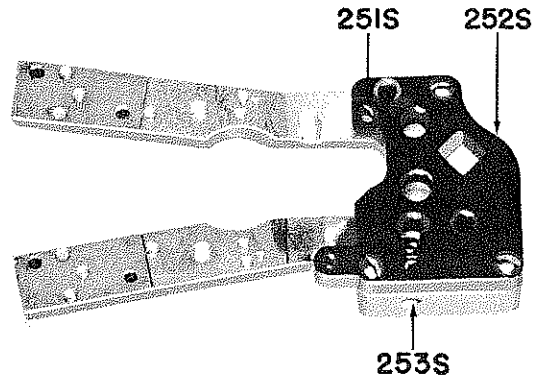

## LOWER GEAR BRACKET ASSEMBLY

List No.	Part Description	Part No.
250S	Lower Gear Bracket (Complete)	715C1-10
251S	Screw (1) for Gear Cover (53C4-76)	6-32x3/8 Fil. H.
252S	Lower Gear Bracket with Cover	715C1-11
253S	Grease Plug	54C4-35
254S	Guide Back of Standard	70C4-23
255S	Lower Gear Bracket Gear Cover	53C4-76
256S	Screws (2) for Guide Back (70C4-23)	6-32x1/4R.H.
257S	Adjusting Screw	20C6-22
258S	Screws (3) for Gear Cover (53C4-76)	6-32x1/2R.H.
259S	Clamping Arm for Shoe	35C7-26
260S	Screw for Clamping Arm	20C12-143
261S	Spring for Arm	34C10-123
262S	Stabilizers (2)	728C1-5
263S	Screws (4) for Stabilizers (728C1-5)	4-36x1/4 Fil.H.
264S	Bearing for Intermediate Gear (87C5-13)	90C4-47
265S	Intermediate Gear	87C5-13
266S	R.H. Shaft Extension	147C1-28
267S	Collar for Lower Screw Shaft (713C2-X)	5C5-16
268S	Bearings (2) for Shaft Extension	90C4-59
269S	L.H. Shaft Extension	147C1-29
270S	Nuts (2) for Sharpener Shoes Screws	4C2-63
271S	Screws (2) for Sharpener Shoes	20C12-57
272S	L.H. Sharpener Shoe Spring	34C10-47
273S	R.H. Sharpener Shoe Spring	34C10-57
274S	Neoprene Bands (2) for Pulley	209C1
275S	Front Pulleys (2) for Belts	152C1-19
275Sa	Roll Pin (2) for Pulleys (152C1-19)	17C15-103
276S	Bearing for Screw Shaft	90C4-51
277S	Gear on Screw Shaft	87C3-50
278S	L.H. Slide with Pulley	712C1-1
279S	R.H. Slide with Pulley	712C1
280S	Spring (2) for Pulley Slide	34C10-45
281S	R.H. Shoe with Bushing	743C1-11
282S	L.H. Shoe with Bushing	743C1-18
283S	L.H. Shoe with Bushing for Plastic Master	743C1-4
284S	Set Screw (1) for Sharpener Shoes	20C13-4

### IMPORTANT ORDERING INSTRUCTIONS

Number in parenthesis indicates number of parts per assembly. Where the letter X follows a part number, be sure to give the model and serial numbers shown on the machine for which the part is required.

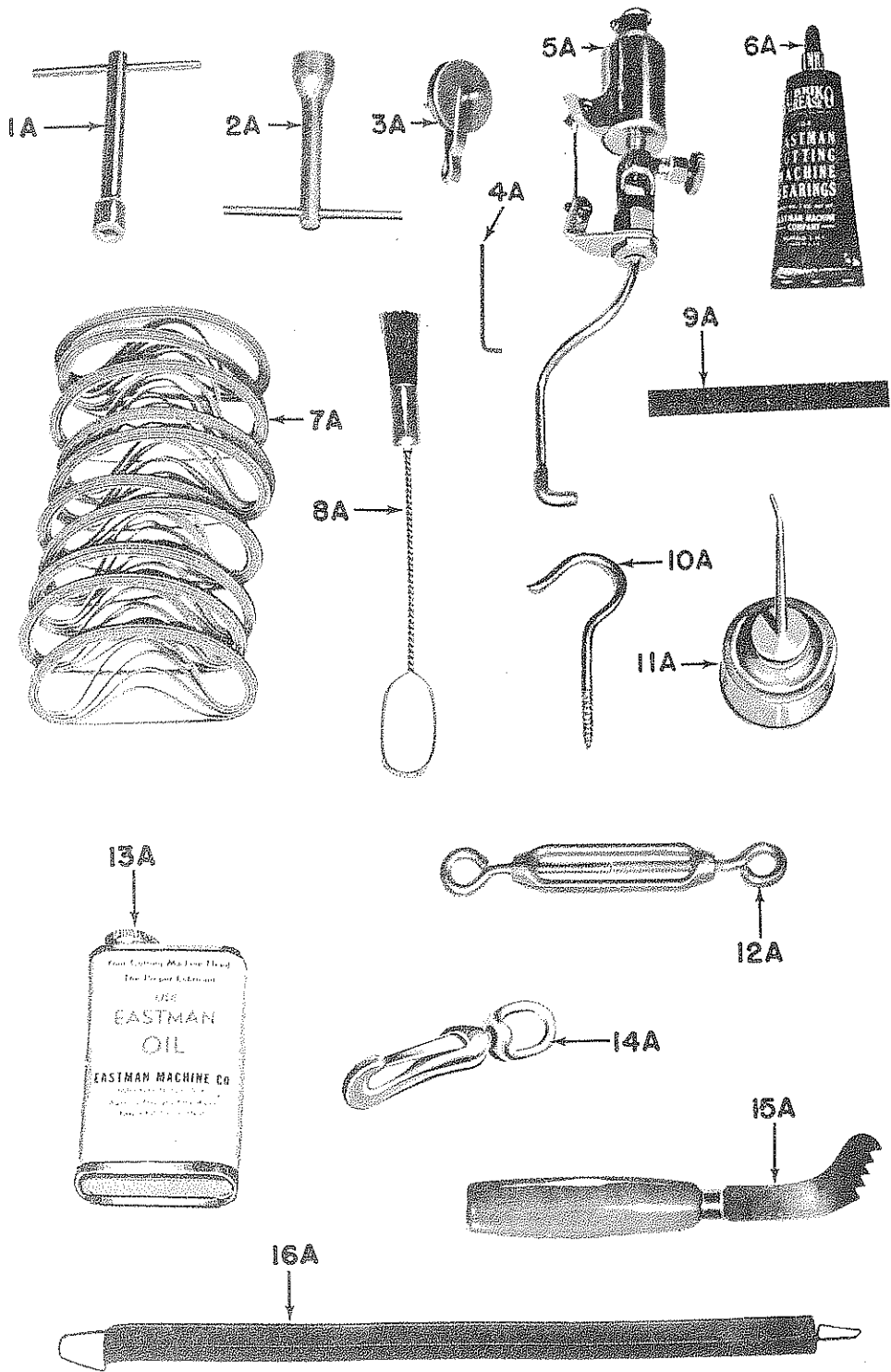

## ACCESSORIES

List No.	Part Description
1A	Knife Bolt Wrench
2A	Plate Bolt Wrench
3A	Trolley Pulley
4A	Allen Wrench for Shoe Set Screws
5A	Oiling Device
6A	Eastman Bearing Grease
7A	Abrasive Belts (See Page 28)
8A	Sharpener Cleaning Brush
9A	Feeler Guage for Shoe Set Screws
10A	Trolley Hook
11A	Oil Can
12A	Turnbuckle
13A	1/2 Pint Eastman Oil
14A	Swivel Snap
15A	Slot Cleaner
16A	Trolley Spring

### GUARANTEE

We guarantee our machines for six months from date of invoice against defective parts and workmanship and will repair or replace any machine going wrong from these causes when returned to us carrying charges prepaid.

This guarantee does not contemplate making good damage caused by misuse or neglect.

**EASTMAN MACHINE COMPANY**

# KNIVES AND ABRASIVE BELTS



Straight



Saw Tooth



Wave

KNIVES				
SIZE	TYPE	CARBON	HIGH SPEED	SPECIAL ALLOY
5"	Straight	80C5	80C5HS	80C5SA
5"	Saw Tooth	80C5-14	80C5-14HS	
5"	Wave	80C5-19	80C5-19HS	
6"	Straight	80C6	80C6HS	80C6SA
6"	Saw Tooth	80C6-14	80C6-14HS	
6"	Wave	80C6-19	80C6-19HS	
7"	Straight	80C7	80C7HS	80C7SA
7"	Saw Tooth	80C7-14		
7"	Wave	80C7-19	80C7-19HS	
8"	Straight	80C8	80C8HS	80C8SA
8"	Saw Tooth	80C8-7		
8"	Wave	80C8-19	80C8-19HS	
9"	Straight	80C9	80C9HS	80C9SA
9"	Wave	80C9-19	80C9-19HS	
10"	Straight	80C10	80C10HS	80C10SA
10"	Wave	80C10-19	80C10-19HS	

ABRASIVE SHARPENING BELTS		
(Packed in Boxes of 100)		
GRIT	COLOR CODE	NUMBER
Rough	Black	181C1-6
Coarse	Red	181C2-1
Medium	Green	181C2-2
Fine	Blue	181C2-5